

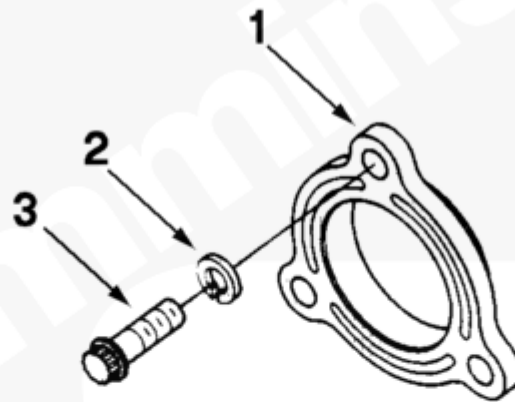

Parts Catalog - Option Detail

Electronic Parts Catalog - Option Detail				
Option	Group	Graphic	Film Card	Date
SM1703-03	13.05.1	sm100gl	FF	01-JAN-01
Engines	G855, G855 CM558, GTA855 CM558 (CM2358) G101, N14 CELECT, N14 CELECT PLUS, N14 MECHANICAL, NH/NT 855, QSM11 CM876 M101, QSM11 CM876 M102M, QSN14 CM876 N103, QSN14 CM876 N105, QSNT14 CM876 N102			

©Cummins Inc



sm100gl

[SMALL](#) | [MEDIUM](#) | [LARGE](#)

Cart	Ref No	Part Number	Part Description	Required	Remarks
View My Cart					
		SM1703-03	Starting Motor Mounting		
					Used only with dry cast iron
					flywheel housing. For use
					without magnetic switch
					options. Mounting supplied

					by Cummins. Motor may be
					supplied by either Cummins or
					the customer. Flywheel
					housing may be supplied by
					either Cummins or the
					customer.
<input type="checkbox"/>	1	9245	Starting Motor Spacer	1	
<input type="checkbox"/>	2	S 603	Lock Washer	3	5/8 in.
<input type="checkbox"/>	3	153581	Twelve Point Cap Screw	3	5/8 - 11 x 2 in.

© 2019 Cummins Inc., Box 3005, Columbus, IN 47202-3005 U.S.A.
Terms of Use and Disclaimers | Recommended System Requirements
Need Assistance? Please click on the Contact Us button in the top right corner of any page.